

ROUND STEP & FLOOR SWIRL DIFFUSER

We Care For The Air You Breathe



Round Step & Floor Swirl Diffuser Index

ROUND STEP SWIRL DIFFUSER (RSSD)	Q1
PRODUCT FEATURES	Q1
INSTALLATION	Q1
ROUND FLOOR SWIRL DIFFUSER (RFSD)	Q1
PRODUCT FEATURES	Q1
BREAKING STATIC LOAD	Q1
EFFECTIVE AREA OF SUPPLY AIR	Q1

ROUND STEP SWIRL DIFFUSER (RSSD)

PRODUCT FEATURES

Used in theatres, halls, music halls, cinemas and other places.
The diffuser is installed on the vertical side of steps or on the ground.
There are four sections on the panel for blowing air producing a swirl motion.
Every blade is vertical to each other.
The seams on the panel guarantee a horizontal blow.
The panel is fixed to the internal beam by central bolt with a trim lid to cover.
For better conformability, the max. temperature difference shall not exceed +/- 6T.

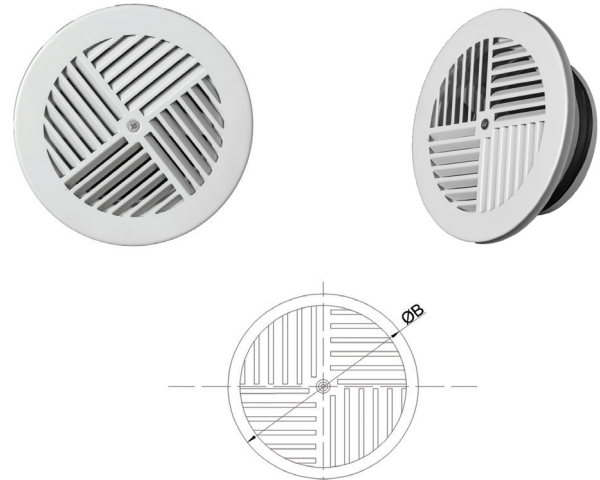

INSTALLATION

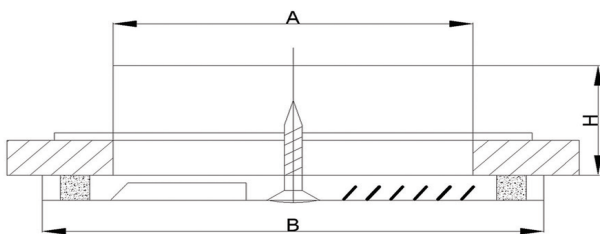

DIMENSION

A (mm)	B (mm)	H (mm)
80	160	100
100	160	100
120	160	100
150	180	100
200	250	150

ROUND FLOOR SWIRL DIFFUSER (RFSD)

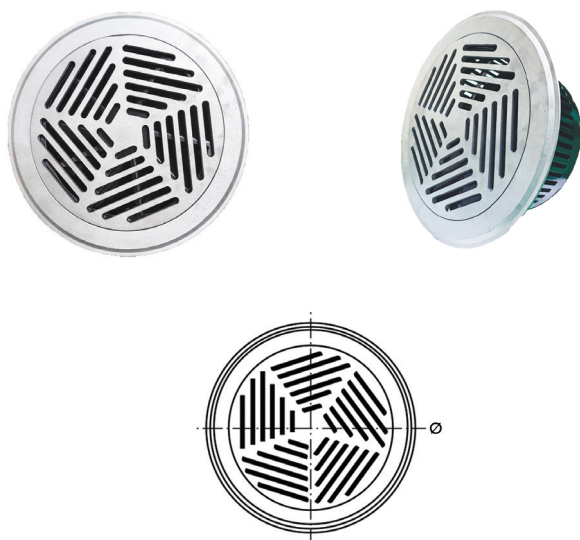

PRODUCT FEATURES

Round Floor Swirl Diffuser are mounted in the floor.
It is manufactured in cast Aluminium, drip trap and internal swirl constructed in galvanized steel sheet.

High induction levels

Sizes available are 150 Ø and 200 Ø

BREAKING STATIC LOAD

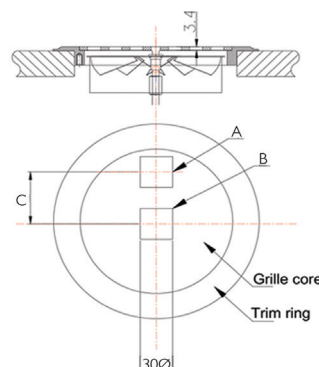

Size		150Ø	200Ø
Breaking Load (Kg)	Load Position A	128	117
	Load Position B	98	82
Load Position C		52	77
Remarks			

EFFECTIVE AREA OF SUPPLY AIR

Size	150 Ø	200 Ø
Area of Supply Air (m ²)	0.0048	0.0172